

IM2066  
09/2015  
REV01

# VIKING™ 1740 SERIES AUTO-DARKENING HELMETS

---

OPERATOR'S MANUAL



GRAPHICS MAY VARY

ENGLISH

---

**LINCOLN**®  
**ELECTRIC**

LINCOLN ELECTRIC EUROPE S.L  
c/o Balmes, 89 - 8<sup>o</sup> 2<sup>a</sup>, 08008 Barcelona, Spain  
[www.lincolnelectric.eu](http://www.lincolnelectric.eu)

Declaration of conformity



## **Lincoln Electric Europe**

Declares that the welding helmets:

Viking 1740 Series

conform to the following directives:

**89/686 EWG**

and has been designed in compliance with the following standards:

**EN 379, EN 166, EN 175**



29<sup>th</sup> April 2015

Pietro Terranova

Accessories Product Manager EMEA

Lincoln Electric Europe S.L, c/o Balmes, 89 – 8<sup>o</sup> 2<sup>a</sup>, 08008 Barcelona, Spain

12/05

**THANKS!** For having chosen the **QUALITY** of the Lincoln Electric products.

- Please Examine Package and Equipment for Damage. Claims for material damaged in shipment must be notified immediately to the dealer.
- For future reference record in the table below your equipment identification information. Model Name, Code & Serial Number can be found on the machine rating plate.

Model Name:
Code & Serial number:
Date & Where Purchased:

## ENGLISH INDEX

Safety .....	1
Preparation and Operator Instructions .....	2
Helmet Information .....	3
Specifications .....	4
Operating Instructions.....	5
Cartridge Operation/Features .....	6
Marking.....	7
Helmet Care and Maintenance .....	8
Shade Guide Settings.....	8
Cartridge and Lens Replacement .....	9
TroubleShooting Guide.....	10
WEEE .....	11
Spare Parts.....	11
Warranty Information .....	11
Replacement Parts .....	12
Optional Accessories .....	12



# WARNING

This equipment must be used by qualified personnel. Be sure that all installation, operation, maintenance and repair procedures are performed only by qualified person. Read and understand this manual before operating this equipment. Failure to follow the instructions in this manual could cause serious personal injury, loss of life, or damage to this equipment. Read and understand the following explanations of the warning symbols. Lincoln Electric is not responsible for damages caused by improper installation, improper care or abnormal operation.

	<p><b>WARNING:</b> This symbol indicates that instructions must be followed to avoid serious personal injury, loss of life, or damage to this equipment. Protect yourself and others from possible serious injury or death.</p>
	<p><b>READ AND UNDERSTAND INSTRUCTIONS:</b> Read and understand this manual before operating this equipment. Arc welding can be hazardous. Failure to follow the instructions in this manual could cause serious personal injury, loss of life, or damage to this equipment.</p>
	<p><b>ELECTRIC SHOCK CAN KILL:</b> Welding equipment generates high voltages. Do not touch the electrode, work clamp, or connected work pieces when this equipment is on. Insulate yourself from the electrode, work clamp, and connected work pieces.</p>
	<p><b>ELECTRICALLY POWERED EQUIPMENT:</b> Turn off input power using the disconnect switch at the fuse box before working on this equipment. Ground this equipment in accordance with local electrical regulations.</p>
	<p><b>ELECTRICALLY POWERED EQUIPMENT:</b> Regularly inspect the input, electrode, and work clamp cables. If any insulation damage exists replace the cable immediately. Do not place the electrode holder directly on the welding table or any other surface in contact with the work clamp to avoid the risk of accidental arc ignition.</p>
	<p><b>ELECTRIC AND MAGNETIC FIELDS MAY BE DANGEROUS:</b> Electric current flowing through any conductor creates electric and magnetic fields (EMF). EMF fields may interfere with some pacemakers, and welders having a pacemaker shall consult their physician before operating this equipment.</p>
	<p><b>CE COMPLIANCE:</b> This equipment complies with the European Community Directives.</p>

 <p>Optical radiation emission Category 2 (EN 12198)</p>	<p><b>ARTIFICIAL OPTICAL RADIATION:</b> According with the requirements in 2006/25/EC Directive and EN 12198 Standard, the equipment is a category 2. It makes mandatory the adoption of Personal Protective Equipments (PPE) having filter with a protection degree up to a maximum of 15, as required by EN169 Standard.</p>
	<p><b>FUMES AND GASES CAN BE DANGEROUS:</b> Welding may produce fumes and gases hazardous to health. Avoid breathing these fumes and gases. To avoid these dangers the operator must use enough ventilation or exhaust to keep fumes and gases away from the breathing zone.</p>
	<p><b>ARC RAYS CAN BURN:</b> Use a shield with the proper filter and cover plates to protect your eyes from sparks and the rays of the arc when welding or observing. Use suitable clothing made from durable flame-resistant material to protect you skin and that of your helpers. Protect other nearby personnel with suitable, non-flammable screening and warn them not to watch the arc nor expose themselves to the arc.</p>
	<p><b>WELDING SPARKS CAN CAUSE FIRE OR EXPLOSION:</b> Remove fire hazards from the welding area and have a fire extinguisher readily available. Welding sparks and hot materials from the welding process can easily go through small cracks and openings to adjacent areas. Do not weld on any tanks, drums, containers, or material until the proper steps have been taken to insure that no flammable or toxic vapors will be present. Never operate this equipment when flammable gases, vapors or liquid combustibles are present.</p>
	<p><b>WELDED MATERIALS CAN BURN:</b> Welding generates a large amount of heat. Hot surfaces and materials in work area can cause serious burns. Use gloves and pliers when touching or moving materials in the work area.</p>
	<p><b>SAFETY MARK:</b> This equipment is suitable for supplying power for welding operations carried out in an environment with increased hazard of electric shock.</p>

## Preparation and Operator Instructions

### General

The welding helmets 1740 SERIES secure proper protection of the eyes during welding. They permanently secure protection against UV and IR radiation and sparks not only in clear but in dark condition as well.

- Shade degree of 1740 SERIES was matched in such a way to protect your eyes against injury by the welding arc.
- Direct looking at the welding arc is forbidden. Arc rays are very dangerous. They can cause painful conjunctivitis and irreparable changes in your pupil.
- Welding helmets 1740 SERIES allow you to observe the welding arc very precisely. You needn't flip it up and down during welding. Both your hands are kept free and because of light weight, the helmet reduces your fatigue and you can gain evident time savings.

### **WARNING**

**Batteries not installed please insert before use.**

When the arc is striking the filter automatically darkens.

## Before welding

- Check the front cover lens and the front lens frame are securely in place.
- Select the shade level you need for your filter setting by the proper knob.
- Adjust headband so that the helmet is seated on the head as low as possible and near to your face. Adjust helmet angle when in the lowered position by turning headgear.
- Press the "Test" button to check the correct operation of the filter

## Special Features

- Eyes are always protected against ultraviolet and infrared rays, regardless of the shade level.
- The switching time of the filter from dark to clear state can be adjusted manually. By the means of a delay time knob the opening time can be adjusted to fast or slow. Before welding adjust your delay time according to your welding process, in order to protect the eyes against residual light of the afterglow of the work materials. The fastest opening time is set at 0.1 sec.

## Important Note

- The helmets are only to be used to protect the eyes and face from radiation and sparks.
- Lincoln Electric does not accept any liability if the helmet is used for another purpose and improperly used. Helmets series Viking are not suitable for laser and gas-welding applications.
- Helmet must never be placed on hot surfaces.
- Never open or tamper with the shade filter.
- Protect the filter from liquid and dirty contact.
- Clean the filter surface regularly.
- Always keep sensors and solar cells clean
- Regularly replace the protective lens with Lincoln Electric originals.

### WARNING

- Do not leave the workplace with the helmet lowered in position; a bright light surface could cause the filter darken unexpectedly.
- Helmets should never be used as sunglasses when driving as this could lead to incorrect identification of the color of traffic lights.
- Materials which may come into contact with the wearer's skin could cause allergic reactions to susceptible individuals.
- Eye protectors against high speed particles worn over standard ophthalmic spectacles may transmit impacts, thus creating a hazard to the wearer .

## Helmet Information

---

This Auto-Darkening Welding Helmet will automatically change from a light state (shade DIN4) to a dark state (shade DIN9-13) when arc welding starts.

The filter automatically returns to a light state when the arc stops.

Match your welding application to the shade indicated on the shade chart. (See Page 8)

- Operating temperature: -5°C ~ 55°C (23°F ~ 131°F).
- Do not use or open the auto-darkening filter if damaged by shock, vibration or pressure.
- Keep the sensors and solar cell clean. Clean the filter cartridge using a soapy water solution and soft cloth which should be damp but not saturated.

This Auto-Darkening Welding Helmet is designed for use with GMAW, GTAW, MMAW welding, or Plasma Arc and air carbon arc cutting.

The cartridge provides protection from harmful UV and IR radiation, in both dark and light states.

The cartridge contains two sensors to detect the light from the welding arc, resulting in the lens darkening to a selected welding shade.

- Do not use solvents or abrasive cleaning detergent.
- If cover lens is spattered or covered with dirt, it should be replaced immediately.
- Use only replacement parts specified in this manual.
- Do not use the helmet without inside and outside cover lenses properly installed.

## Specifications

### Model No.: 1740 SERIES ADF

Optical Class	1 / 1 / 1 / 2
LCD Viewing Area	96 x 42.5mm (3.78 x 1.67in.)
Cartridge size	110 x 90mm (4.33 x 3.54in.)
UV/IR Protection	Up to Shade DIN 16 at all times
Arc Sensors	2
Light State Shade	DIN 4
Variable Welding Shades	DIN 9 to 13
Grind Mode	DIN 4
Shade Control	Dial knob - full adjustment
Power Supply	Solar cells - with replaceable batteries
Low Battery Warning	Red Light
Battery	AAA Alkaline (2 Required)
Power On/Off	Fully automatic
Light to Dark Switching Time	0.00004 sec. (1/25,000 sec.)
Sensitivity Control	Variable
Delay Control (Dark to Light)	0.1 sec. (Short) to 1.0 sec. (Long)
TIG Rating	5 amps
Operating Temperature	-5°C ~ 55°C (23°F ~ 131°F)
Storage Temperature	-20°C ~ 70°C (-4°F ~ 158°F)
Total Weight	Black 528g (18.6 Oz.)
Compliance <sup>(1)</sup>	CE EN166, EN175, EN379 CSA Z94.3, ANSI Z87.1-2010

<sup>(1)</sup>Headgear compliance with ANSI Z87.1 is without sweatband installed.

# Operating Instructions

---

## Headgear Adjustment

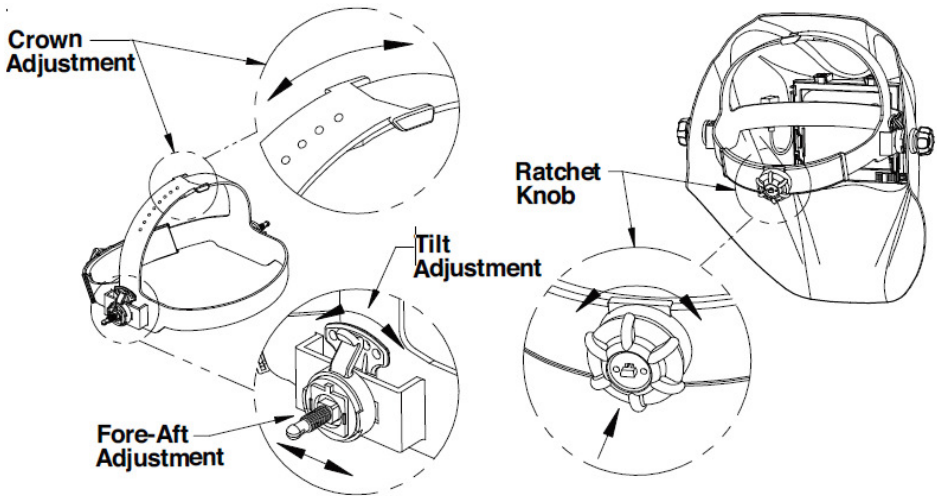

**HEAD SIZE ADJUSTMENT:** HEADGEAR TIGHTNESS is adjusted by pushing in the Ratchet Knob and turning to adjust for the desired head size. This knob is located at the back of the helmet.  
**HEADGEAR CROWN ADJUSTMENT** is made by adjusting for comfort and snapping the pin into the hole to lock securely in place.

**TILT:** Tilt adjustment is located on right side of helmet. Loosen the right headgear tension knob and push the top end of the adjustment lever outward until the lever's Stop Tab clears the notches. Then rotate the lever up or down to the desired tilt position. The Stop will automatically engage again when released locking the helmet into position.

**FORE / AFT ADJUSTMENT:** Adjusts the distance between the user's face and lens. To adjust, loosen the outside tension knobs and slide forward or back to desired position and retighten.

**NOTE:** Make sure both sides are equally positioned for proper operation



# Cartridge Operation/Features

## Variable Shade Control

The shade can be adjusted from shade 9 to 13 based upon welding process or application (refer to shade selection chart on page 8). The variable shade control knob is located on the ADF cartridge as shown below.

## Sensitivity Knob

Adjust the light sensitivity by turning the **SENSITIVITY** knob to the left or right as shown in the figure below. Turning the knob all the way to the right, the **HIGH** setting, is typically selected for normal use. When helmet is used in the presence of excess ambient light or with another welding machine close by, improved helmet performance can be obtained with a lower setting by turning the knob to the left to reduce the sensitivity.

## Weld/Grind switch

Switch to be set to WELD for welding operation. **GRIND** setting is intended for grinding only not for welding

## Delay Knob

This control is designed to protect the welder's eyes from the strong residual rays after welding. Changing the **DELAY** knob will vary the dark to light time between 0.1 second (**SHORT**) to 1.0 second (**LONG**). **LONG** setting is recommended for high amperage applications where the weld puddle is still very bright after the welding arc has ceased and for situations where the filter may be temporarily blocked from seeing the welding arc.

## Power

This ADF cartridge is powered by replaceable batteries and solar power.



### WARNING

**Batteries not installed please insert before use.**

The batteries are located at the bottom of the ADF cartridge. Replace batteries when **LOW BATTERY** light is lit. See the specification chart on page 3 for type of batteries required.

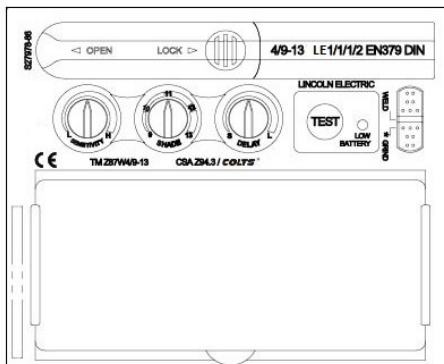

# Marking

---

The shell and the auto darkening filter are marked accordingly. Classification for eye and face protection is following EN379, EN175, EN166.

LINCOLN Auto darkening welding helmet 1740 SERIES

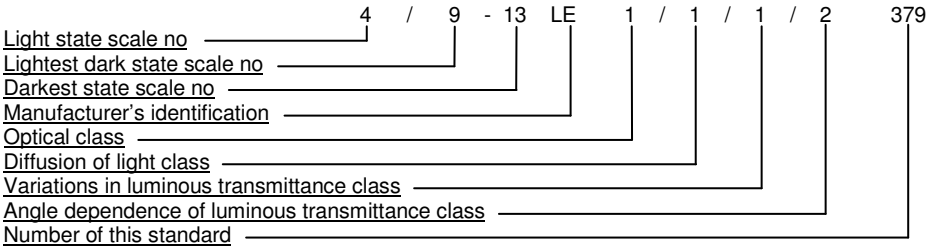

Marking on helmet:

"LE EN 175 B" : LE : manufacturer's identification  
EN 175: number of this standard  
B: resistance to medium energy impact

Marking on front cover lens:

"LE B" : LE : manufacturer's identification  
B: resistance to medium energy impact

Marking on Inside cover lens:

"LE 1 B" : LE : manufacturer's identification  
1 : optical class  
B: resistance to medium energy impact

## WARNING

If protection against high speed particles at extremes of temperature is required then the selected eye-protector should be marked with the letter "T" immediately after the resistance to impact letter. If the impact letter is not followed by the letter "T" then the eye protector shall only be used against high speed particles at room temperature

DIN CERTCO Gesellschaft fuer  
Konformitaetsbewertung mbH  
Alboinstrasse 56  
12103 Berlin

Notified body number 0196

# Helmet Care and Maintenance

**Cleaning:** Clean helmet by wiping with a soft cloth. Clean cartridge surfaces regularly. Do not use strong cleaning solutions. Clean sensors and solar cells with soapy water solution and a clean cloth and wipe dry with a lint-free cloth. Do **NOT** submerge shade cartridge in water or other solution.  
**Storage:** Store in a clean, dry location.

## Shade Guide Settings

Recommended shade numbers according to EN 379:2003

CURRENT IN AMPERE	600	14	14							600				
	500		13							14	600			
	450	13	12	13	14	14	15	13		450				
	400			13	14	400								
	350			12	13	14	350							
	300	12	11	13	12	13	13	12		300				
	250			12	11	12	12			250				
	225	11	10	12	11	11	12	11	11	225				
	200									11	10	11	11	200
	175									10	10	10	10	175
	150	9	9	10	11	10	10	11	10	150				
	125									9	9	9	9	125
	100	8	8	9	9	10	10	9	9	100				
	70									8	8	8	8	70
	60									7	7	7	7	60
	40									6	6	6	6	40
	30	5	5	8	8	8	9	9	8	30				
	15									4	4	4	15	
	10									4	4	4	10	
6	4	4	8	8	8	9	9	4	6					
2									4	4	4	2		
<b>PROCESS</b>		<b>MMAW (STICK ELECTRODES)</b>	<b>MAG</b>	<b>TIG</b>	<b>MIG</b>	<b>MIG WITH LIGHT ALLOYS</b>	<b>AIR-ARC GOUGING</b>	<b>PLASMA JET CUTTING</b>	<b>MICROPLASMA ARC WELDING</b>					

If your helmet does not include any one of the shades referenced above, it is recommended you use the next darker shade.

# Cartridge and Lens Replacement

---

## Replacing Front Clear Cover Lens:



Replace the front cover lens if it is damaged.

Remove ADF holder assembly per Figure 1.

Remove front cover lens from helmet assembly. Carefully remove gasket from cover lens. Install new cover lens into gasket and assemble to helmet shell. Make sure to assemble cover lens and gasket into helmet shell the same way as it was removed.

## Replacing Inside Clear Lens:



Replace the inside clear lens if it is damaged

Remove ADF holder assembly per figure 1. Remove shade cartridge from ADF holder. Place your fingernail in recess below cartridge view window and flex lens upwards until it releases from edges of cartridge view window.

## Change the Shade Cartridge:

Remove ADF holder assembly from helmet shell. See figure 1 for removal. Flex top end of the ADF holder to allow for ADF cartridge to be removed from frame. Install new ADF cartridge into frame per figure 2 below. Make sure that the ADF cartridge is inserted in ADF holder correctly as shown. Install ADF holder assembly into helmet shell.

## INSTALLING AN AFTERMARKET MAGNIFYING LENS:

Simply slide the magnifying lens into the short rail located on the sides of ADF holder per Figure 3. Shade cartridge must be removed from ADF holder to install magnifying lens.

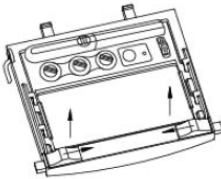

Figure 1



Figure 2

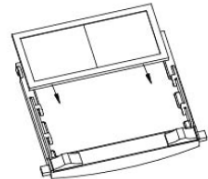



Figure 3

# TroubleShooting Guide

Test your shade cartridge prior to welding by directing the front of the cartridge toward a bright source of light. Then, using your fingers, rapidly cover and uncover the sensors. The cartridge should darken momentarily as the sensor is exposed. A torch striker can also be used.

PROBLEM	POSSIBLE CAUSE	SOLUTION
Difficult to see through filter.	Front cover lens dirty.	Clean or replace front cover lens.
	Cartridge dirty.	Clean the Auto-Darkening cartridge with soapy water solution and soft cloth.
Filter does not darken when arc is struck.	Sensitivity is set too low.	Adjust sensitivity to required level.
	Front cover lens dirty.	Clean or replace front cover lens.
	Front cover lens is damaged.	Check for cracked or pitted front cover lens and replace as required.
	Sensors are blocked or Solar panel is blocked.	Make sure you are not blocking the sensors or solar panels with your arm or other obstacle while welding. Adjust your position so that the sensors can see the weld arc.
	Grind Mode Selected	Check Weld/Grind switch
Filter darkening without arc being struck.	Sensitivity set too high.	Adjust sensitivity to required level.
Filter remains dark after completing a weld.	Delay time set too high.	Adjust delay time to required level.
<b>⚠ WARNING</b>		
	ADF is cracked.	Cease (STOP) using this product if this problem exists. UV/IR protection may be compromised resulting in burns to the eyes and skin.
	Weld spatter is damaging the filter.	Missing, damaged, broken, cracked or distorted front cover lens.

## WEEE

07/06

English



Do not dispose of electrical equipment together with normal waste!

In observance of European Directive 2002/96/EC on Waste Electrical and Electronic Equipment (WEEE) and its implementation in accordance with national law, electrical equipment that has reached the end of its life must be collected separately and returned to an environmentally compatible recycling facility. As the owner of the equipment, you should get information on approved collection systems from our local representative.

By applying this European Directive you will protect the environment and human health!

## Spare Parts

08/12

### Part List reading instructions

- Use the illustration of assembly page and the end of the catalogue to determine where the part is located for your particular code.
- Do not use this part list for an item if its code number is not listed. Contact the Lincoln Electric Service Department for any code number not listed.

First, read the Part List reading instructions above, then refer to the "Replacement Parts" chapter, that contains a picture-descriptive part number cross-reference.

## Warranty Information

### SPATTER DAMAGE IS NOT COVERED BY WARRANTY:

Do not use this product without the correct protective clear lenses installed properly on both sides of the Auto-Darkening Filter cartridge (ADF). The clear lenses supplied with this helmet are properly sized to work with this product and substitutions from other suppliers should be avoided.

# Replacement Parts

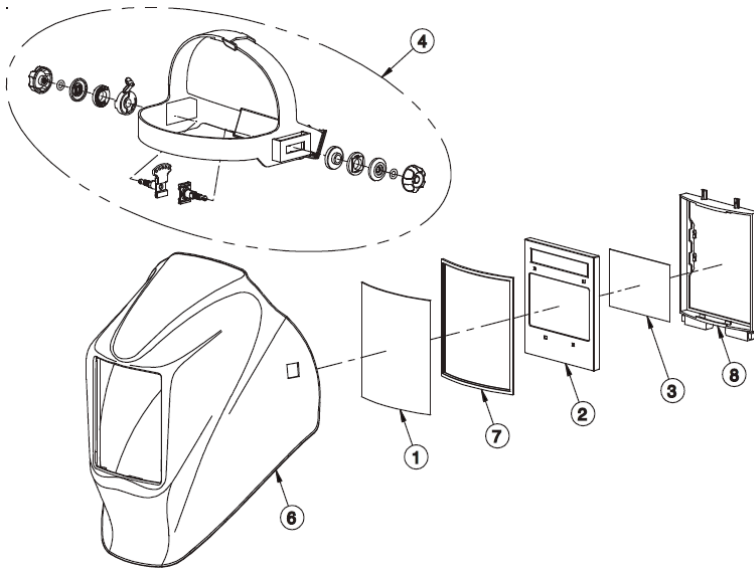

ITEM	PART NO.	DESCRIPTION	QTY
1	KP3043-1	OUTSIDE CLEAR LENS (PKG. QTY: 5)	1
2	KP3284-1	ADF CARTRIDGE (S27978-86)	1
3	KP3283-1	INSIDE CLEAR LENS (PKG. QTY: 5)	1
4	KP2929-1	HEADGEAR ASSEMBLY (INCLUDING SWEATBAND)	1
5*	KP2930-1	SWEATBAND (PKG. QTY: 2)	1
6	KP3282-SH	REPLACEMENT SHELL (VH10)	1
7	S27978-58	OUTSIDE CLEAR LENS SEAL	1
8	S27978-55	ADF HOLDER	1

\*Not illustrated

# Optional Accessories

ITEM	PART NO.	DESCRIPTION	QTY
1	KP3046-100	CHEATER LENS 1.00 MAGNIFICATION	1
2	KP3046-125	CHEATER LENS 1.25 MAGNIFICATION	1
3	KP3046-150	CHEATER LENS 1.50 MAGNIFICATION	1
4	KP3046-175	CHEATER LENS 1.75 MAGNIFICATION	1
5	KP3046-200	CHEATER LENS 2.00 MAGNIFICATION	1
6	KP3046-225	CHEATER LENS 2.25 MAGNIFICATION	1
7	KP3046-250	CHEATER LENS 2.50 MAGNIFICATION	1