

# WELD PAK™ 2000

---

OPERATOR'S MANUAL



ENGLISH



Lincoln Electric Bester Sp. z o.o.  
ul. Jana III Sobieskiego 19A, 58-263 Bielawa, Poland  
[www.lincolnelectric.eu](http://www.lincolnelectric.eu)



Declaration of conformity



**Lincoln Electric Bester Sp. z o.o.**

Declares that the welding machine:

**WELD PAK™ 2000**

conforms to the following directives:

**2014/35/EU , 2014/30/EU**

and has been designed in compliance with the following standards:

**EN 60974-1:2012, EN 60974-5:2013,  
EN 60974-10:2014**

A handwritten signature in black ink, consisting of several overlapping loops and a long horizontal stroke extending to the right.

20.04.2016

Piotr Szytek  
Operations Director

Lincoln Electric Bester Sp. z o.o., ul. Jana III Sobieskiego 19A, 58-263 Bielawa, Poland

07/11



**THANKS!** For having chosen the QUALITY of the Lincoln Electric products.

- Please Examine Package and Equipment for Damage. Claims for material damaged in shipment must be notified immediately to the dealer.
- For future reference record in the table below your equipment identification information. Model Name, Code & Serial Number can be found on the machine rating plate.

|                         |       |
|-------------------------|-------|
| Model Name:             |       |
| .....                   |       |
| Code & Serial number:   |       |
| .....                   | ..... |
| Date & Where Purchased: |       |
| .....                   | ..... |

## ENGLISH INDEX

|  |    |
|--|----|
| Technical Specifications .....               | 1  |
| Electromagnetic Compatibility (EMC) .....    | 2  |
| Safety .....                                 | 3  |
| Introduction .....                           | 4  |
| Installation and Operator Instructions ..... | 4  |
| WEEE .....                                   | 13 |
| Spare Parts .....                            | 13 |
| Electrical Schematic .....                   | 13 |
| Suggested Accessories .....                  | 13 |

# Technical Specifications

## WELD PAK™ 2000

| NAME  |                      | INDEX  |                                  |                      |
|---|----------------------|--|----------------------------------|----------------------|
| WELD PAK™2000                               |                      | K14134-1                                       |                                  |                      |
| INPUT                                       |                      |  |                                  |                      |
| Input Voltage U <sub>1</sub>                |                      | EMC Class                                      | Frequency                        |                      |
| 230 V ± 10%<br>1 – phase                    |                      | A  | 50 / 60 Hz                       |                      |
| Input Power at Rated Cycle                  |                      | Input Amperes<br>I <sub>1max</sub>             | PF                               |                      |
| 7,6 kVA @ 20 % Duty Cycle (40°C)            |                      | 33 A   | 0,66                             |                      |
| RATED OUTPUT                                |                      |  |                                  |                      |
|   | Open Circuit Voltage | Duty Cycle 40°C<br>(based on a 10 min. period) | Output Current                   | Output Voltage       |
| GMAW  | 49 Vdc               | 100  | 80 A                             | 18 Vdc               |
|   |                      | 20   | 180 A                            | 23 Vdc               |
| FCAW-SS                                     | 49 Vdc               | 100  | 80 A                             | 18 Vdc               |
|   |                      | 20   | 180 A                            | 23 Vdc               |
| SMAW  | 49 Vdc               | 100  | 80 A                             | 23,2 Vdc             |
|   |                      | 20   | 160 A                            | 26,4 Vdc             |
| WELDING CURRENT RANGE                       |                      |  |                                  |                      |
| GMAW  |                      | FCAW-SS  |                                  | SMAW                 |
| 20 A – 180 A                                |                      | 20 A – 180 A                                   |                                  | 20 A – 160 A         |
| RECOMMENDED INPUT CABLE AND FUSE SIZES      |                      |  |                                  |                      |
| Fuse (time delayed) or Circuit Breaker Size |                      |  | Power Lead                       |                      |
| 230 V                                       |                      |  |                                  |                      |
| D 25 A                                      |                      |  | 3 Conductor, 1,5 mm <sup>2</sup> |                      |
| DIMENSIONS AND WEIGHT                       |                      |  |                                  |                      |
| Weight                                      |                      | Height   |                                  | Length               |
| 27,5 kg                                     |                      | 600 mm   |                                  | 800 mm               |
| Protection Rating                           |                      | Operating Temperature                          |                                  | Storage Temperature  |
| IP23  |                      | from -10 °C to +40 °C                          |                                  | from -25 °C o +55 °C |

# Electromagnetic Compatibility (EMC)

01/11

This machine has been designed in accordance with all relevant directives and standards. However, it may still generate electromagnetic disturbances that can affect other systems like telecommunications (telephone, radio, and television) or other safety systems. These disturbances can cause safety problems in the affected systems. Read and understand this section to eliminate or reduce the amount of electromagnetic disturbance generated by this machine.



This machine has been designed to operate in an industrial area. The operator must install and operate this equipment as described in this manual. If any electromagnetic disturbances are detected the operator must put in place corrective actions to eliminate these disturbances with, if necessary, assistance from Lincoln Electric

Before installing the machine, the operator must check the work area for any devices that may malfunction because of electromagnetic disturbances. Consider the following.

- Input and output cables, control cables, and telephone cables that are in or adjacent to the work area and the machine.
- Radio and/or television transmitters and receivers. Computers or computer controlled equipment.
- Safety and control equipment for industrial processes. Equipment for calibration and measurement.
- Personal medical devices like pacemakers and hearing aids.
- Check the electromagnetic immunity for equipment operating in or near the work area. The operator must be sure that all equipment in the area is compatible. This may require additional protection measures.
- The dimensions of the work area to consider will depend on the construction of the area and other activities that are taking place.

Consider the following guidelines to reduce electromagnetic emissions from the machine.

- Connect the machine to the input supply according to this manual. If disturbances occur it may be necessary to take additional precautions such as filtering the input supply.
- The output cables should be kept as short as possible and should be positioned together. If possible connect the work piece to ground in order to reduce the electromagnetic emissions. The operator must check that connecting the work piece to ground does not cause problems or unsafe operating conditions for personnel and equipment.
- Shielding of cables in the work area can reduce electromagnetic emissions. This may be necessary for special applications.

## **WARNING**

The Class A equipment is not intended for use in residential locations where the electrical power is provided by the public low-voltage supply system. There can be potential difficulties in ensuring electromagnetic compatibility in those locations, due to conducted as well as radio-frequency disturbances.



## **WARNING**

This equipment does not comply with IEC 61000-3-12. If it is connected to a public low voltage system, it is the responsibility of the installer or user of the equipment to ensure, by consultation with the distribution network operator, that the equipment may be connected.

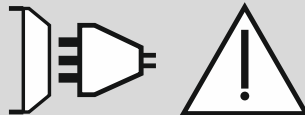





## WARNING

This equipment must be used by qualified personnel. Be sure that all installation, operation, maintenance and repair procedures are performed only by qualified person. Read and understand this manual before operating this equipment. Failure to follow the instructions in this manual could cause serious personal injury, loss of life, or damage to this equipment. Read and understand the following explanations of the warning symbols. Lincoln Electric is not responsible for damages caused by improper installation, improper care or abnormal operation.

|  |   |
|--|---|
|  | <p><b>WARNING:</b> This symbol indicates that instructions must be followed to avoid serious personal injury, loss of life, or damage to this equipment. Protect yourself and others from possible serious injury or death.</p>   |
|  | <p><b>READ AND UNDERSTAND INSTRUCTIONS:</b> Read and understand this manual before operating this equipment. Arc welding can be hazardous. Failure to follow the instructions in this manual could cause serious personal injury, loss of life, or damage to this equipment.</p>  |
|  | <p><b>ELECTRIC SHOCK CAN KILL:</b> Welding equipment generates high voltages. Do not touch the electrode, work clamp, or connected work pieces when this equipment is on. Insulate yourself from the electrode, work clamp, and connected work pieces.</p>  |
|  | <p><b>ELECTRICALLY POWERED EQUIPMENT:</b> Turn off input power using the disconnect switch at the fuse box before working on this equipment. Ground this equipment in accordance with local electrical regulations.</p>   |
|  | <p><b>ELECTRICALLY POWERED EQUIPMENT:</b> Regularly inspect the input, electrode, and work clamp cables. If any insulation damage exists replace the cable immediately. Do not place the electrode holder directly on the welding table or any other surface in contact with the work clamp to avoid the risk of accidental arc ignition.</p>   |
|  | <p><b>ELECTRIC AND MAGNETIC FIELDS MAY BE DANGEROUS:</b> Electric current flowing through any conductor creates electric and magnetic fields (EMF). EMF fields may interfere with some pacemakers, and welders having a pacemaker shall consult their physician before operating this equipment.</p>  |
|  | <p><b>CE COMPLIANCE:</b> This equipment complies with the European Community Directives.</p>  |
|  | <p><b>ARTIFICIAL OPTICAL RADIATION:</b> According with the requirements in 2006/25/EC Directive and EN 12198 Standard, the equipment is a category 2. It makes mandatory the adoption of Personal Protective Equipments (PPE) having filter with a protection degree up to a maximum of 15, as required by EN169 Standard.</p>  |
|  | <p><b>FUMES AND GASES CAN BE DANGEROUS:</b> Welding may produce fumes and gases hazardous to health. Avoid breathing these fumes and gases. To avoid these dangers the operator must use enough ventilation or exhaust to keep fumes and gases away from the breathing zone.</p>  |
|  | <p><b>ARC RAYS CAN BURN:</b> Use a shield with the proper filter and cover plates to protect your eyes from sparks and the rays of the arc when welding or observing. Use suitable clothing made from durable flame-resistant material to protect you skin and that of your helpers. Protect other nearby personnel with suitable, non-flammable screening and warn them not to watch the arc nor expose themselves to the arc.</p>   |
|  | <p><b>WELDING SPARKS CAN CAUSE FIRE OR EXPLOSION:</b> Remove fire hazards from the welding area and have a fire extinguisher readily available. Welding sparks and hot materials from the welding process can easily go through small cracks and openings to adjacent areas. Do not weld on any tanks, drums, containers, or material until the proper steps have been taken to insure that no flammable or toxic vapors will be present. Never operate this equipment when flammable gases, vapors or liquid combustibles are present.</p> |
|  | <p><b>WELDED MATERIALS CAN BURN:</b> Welding generates a large amount of heat. Hot surfaces and materials in work area can cause serious burns. Use gloves and pliers when touching or moving materials in the work area.</p>   |

|   |   |
|---|---|
|  | SAFETY MARK: This equipment is suitable for supplying power for welding operations carried out in an environment with increased hazard of electric shock.   |
|  | CYLINDER MAY EXPLODE IF DAMAGED: Use only compressed gas cylinders containing the correct shielding gas for the process used and properly operating regulators designed for the gas and pressure used. Always keep cylinders in an upright position securely chained to a fixed support. Do not move or transport gas cylinders with the protection cap removed. Do not allow the electrode, electrode holder, work clamp or any other electrically live part to touch a gas cylinder. Gas cylinders must be located away from areas where they may be subjected to physical damage or the welding process including sparks and heat sources. |
|  | MOVING PARTS ARE DANGEROUS: There are moving mechanical parts in this machine, which can cause serious injury. Keep your hands, body and clothing away from those parts during machine starting, operating and servicing.   |

The manufacturer reserves the right to make changes and/or improvements in design without upgrade at the same time the operator's manual.

## Introduction

The welding machines **WELD PAK™ 2000** enables welding:

- GMAW (MIG/MAG)
- FCAW-SS
- SMAW (MMA)

The following equipment has been added to **WELD PAK™ 2000**:

- Bracket with rear wheels, M6 screws (4 units) and M6 lock nuts (4 units)
- Gun for GMAW process – 3m
- Work lead – 3m
- Gas hose – 2m
- Gun holder, M6 screw and M6 lock nut

For GMAW and FCAW-SS process, the technical specification describes:

- Type of welding wire
- Wire diameter

Recommended equipment, which can be bought by user, was mentioned in the chapter "Accessories".

## Installation and Operator Instructions

Read this entire section before installation or operation of the machine.

### Location and Environment

This machine will operate in harsh environments. However, it is important that simple preventative measures are followed to assure long life and reliable operation:

- Do not place or operate this machine on a surface with an incline greater than 15° from horizontal.
- Do not use this machine for pipe thawing.
- This machine must be located where there is free circulation of clean air without restrictions for air movement to and from the air vents. Do not cover the machine with paper, cloth or rags when switched on.
- Dirt and dust that can be drawn into the machine should be kept to a minimum.
- This machine has a protection rating of IP23. Keep it dry when possible and do not place it on wet ground or in puddles.
- Locate the machine away from radio controlled machinery. Normal operation may adversely affect the operation of nearby radio controlled machinery, which may result in injury or equipment damage. Read the section on electromagnetic compatibility in this manual.
- Do not operate in areas with an ambient temperature greater than 40°C.

### Duty cycle and Overheating

The duty cycle of a welding machine is the percentage of time in a 10 minute cycle at which the welder can operate the machine at rated welding current.

Example: 60% duty cycle



Welding for 6 minutes.

Break for 4 minutes.

Excessive extension of the duty cycle will cause the thermal protection circuit to activate.

The machine is protected from overheating by a temperature sensor.

## Input Supply Connection

### WARNING

Only a qualified electrician can connect the welding machine to the supply network. Installation had to be made in accordance with the appropriate National Electrical Code and local regulations.

Check the input voltage, phase and frequency supplied to this machine before turning it on. Verify the connection of ground wires from the machine to the input source. The welding machine **WELD PAK™ 2000** must be connected to a correctly installed plug-in socket with an earth pin.

Input voltage is 1x230V, 50/60Hz. For more information about input supply refer to the technical specification section of this manual and to the rating plate of the machine.

Make sure that the amount of mains power available from the input supply is adequate for normal operation of the machine. The necessary delayed fuse (or circuit breaker with "D" characteristic) and cable sizes are indicated in the technical specification section of this manual.

### WARNING

The welding machine can be supplied from an engine driven generator of output power at least 30% larger than input power of the welding machine. Engine driven generator must have voltage stabilization. Otherwise, may cause a damage. See "Technical Specifications" chapter.

### WARNING

When powering welder from a generator be sure to turn off welder first, before generator is shut down, in order to prevent damage to welder!



## Output Connections

Refer to points [8], [9] and [10] of the Figures below.

## Controls and Operational Features

1. Power Switch ON/OFF (I/O): Controls the input power to the machine. Be sure the power source is connected to the mains supply before turning power on ("I"). After input power is connected and the power switch is turned on, the indicator will light up to indicate the machine is ready to weld.

2. Process Welding's Switch:

|   |   |
|---|---|
|  | GMAW (MIG/MAG) process<br><b>Warning:</b> Can be used to FCAW-SS process. |
|  | SMAW (MMA) process  |

### WARNING

When the machine is switched again on, last welding process will be recalled.

### WARNING

If the push-button is pushed in GMAW process in, the output terminals will lived.

### WARNING

During SMAW process, the output terminals are still lived.

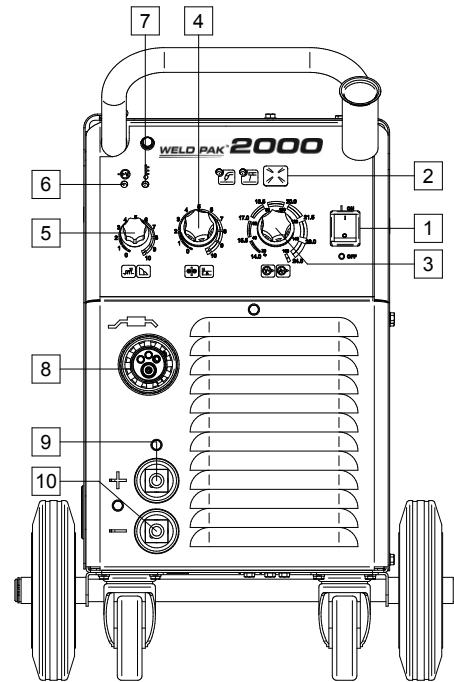





Figure 1



3. Welding Load Voltage / Current Control: Depending on welding process, this knob controls:

|              |  |  |
|--------------|--|--|
| GMAW process |  | The welding load voltage and set by this knob [6] (also during welding). |
| SMAW process |  | The welding current is set by this knob [6] (also during welding).       |



4. WFS/Hot Start Control: Depending on welding process, this knob controls:

|              |  |   |
|--------------|--|---|
| GMAW process |  | <u>Wire feed speed WFS</u> : Value in percentage of nominal value wire feed speed.  |
| SMAW process |  | <u>HOT START</u> : Value in percentage of nominal value welding current during arc start current. The control is used to set the level of the increased current and arc start current is made easy. |

5. Control: Depending on welding process, this knob controls:



|              |  |   |
|--------------|--|---|
| GMAW process |  | <u>Inductance</u> : Arc control is controlled by this knob. If the value is higher, the arc will be softer and during welding is less spatters. |
| SMAW process |  | <u>ARC FORCE</u> : The output current is temporarily increased to clear short circuit connections between the electrode and the workpiece.      |



6. **LED Indicator Power switch:** This LED lights up when the welding machine is ON and is ready to work 
7. **Thermal Overload Indicator:** It indicates that the machine is overloaded or that the cooling is not sufficient. 

 **WARNING**

If the welding current exceed 200 A, output power will be turned off after 5 seconds. It will be indicated by Thermal Overload Indicator. Output power will be turned on again after 3 minutes.

8. **EURO Socket:** For connecting a welding gun (for GMAW / FCAW-SS process).
9. **Positive Output Socket for the Welding Circuit:** For connecting an electrode holder with lead / work lead. 
10. **Negative Output Socket for the Welding Circuit:** For connecting an electrode holder with lead / work lead. 
11. **Gas Connector:** Connection for gas line. 
12. **Power Lead with Plug (3m):** Power lead with plug is a standard equipment. Connect the power lead with plug to the main supply before turning power on.

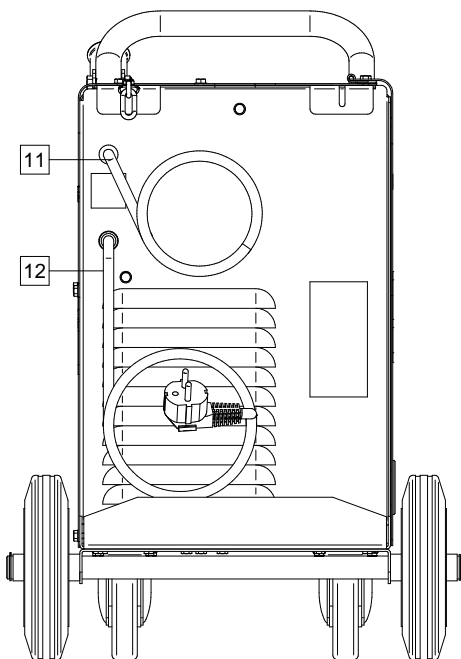

Figure 2.

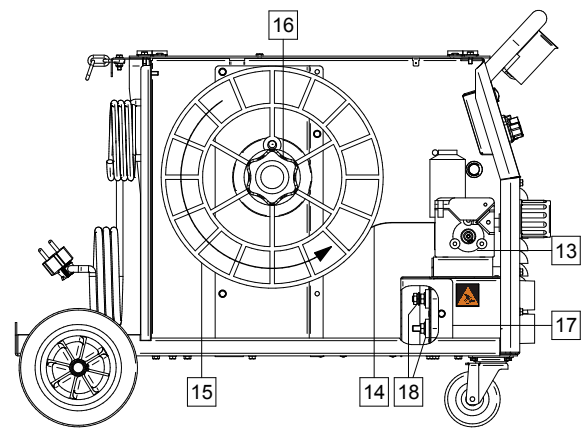

Figure 3

13. **Wire Drive (for GMAW, FCAW-SS process):** 2-Roll wire drive.
14. **Welding Wire (for GMAW / FCAW-SS).**
15. **Spooled Wire (for GMAW / FCAW-SS):** The machine does not include a spooled wire.
16. **Wire Spool Support:** Maximum 15kg spools. Accepts plastic, steel and fiber spools onto 51mm spindle. Also accepts Readi-Reel® type spools onto included spindle adapter.
17. **Shield of Changing Polarity.**
18. **Terminal Block of Changing Polarity (for GMAW / FCAW-SS process):** This terminal block enables to set the welding polarity (+ ; -), which will be given at the welding holder.

 **WARNING**

Positive (+) polarity is set at the factory.

 **WARNING**

Before welding check the polarity for using electrodes and wires.

If the welding polarity has to be changed, user should:

- Switch off the machine.
- Determine the wire polarity for the wire to be used. Consult the electrode data for this information.
- Take off the terminal block's shield [17].
- The tip of the wire on the terminal block [18] and work lead fix as is shown in the Table 1 or the Table 2.
- Put on the terminal block's shield.

 **WARNING**

The machine must be used with the door completely closed during welding.

 **WARNING**

Not use handle to move the machine during work.

Table 1.

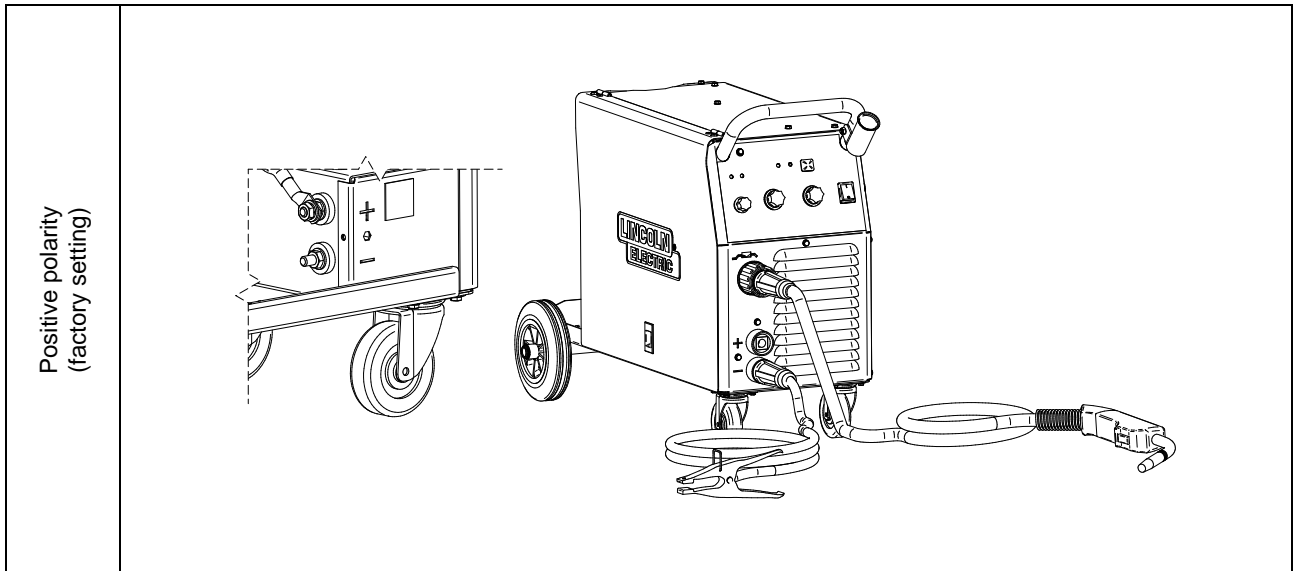
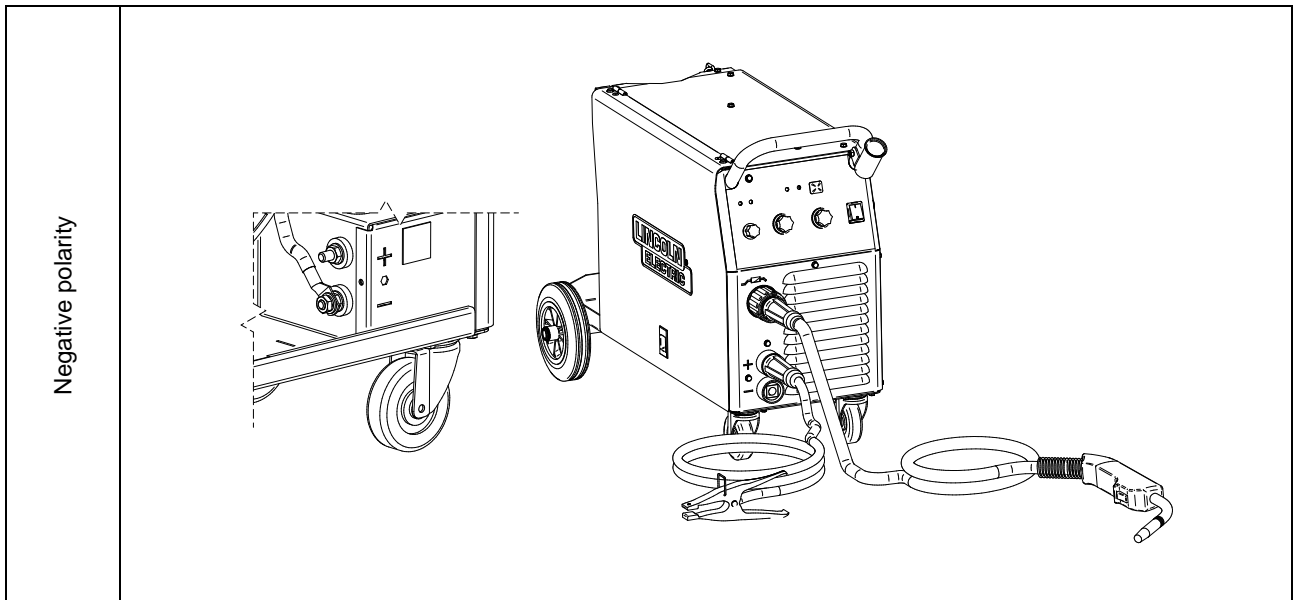

Table 2.



## Wire Spool Loading

Wire spool type S300 and BS300 can be installed on the wire spool support without adapter.

Wire spool type S200, B300 or Readi-Reel® can be installed, but the applicable adapter must be purchased. The applicable adapter can be purchased separately(see "Accessories" chapter).

### Wire Spool Type S300 & BS300 Loading

#### WARNING

Turn the input power OFF at the welding power source before installation or changing a wire spool.

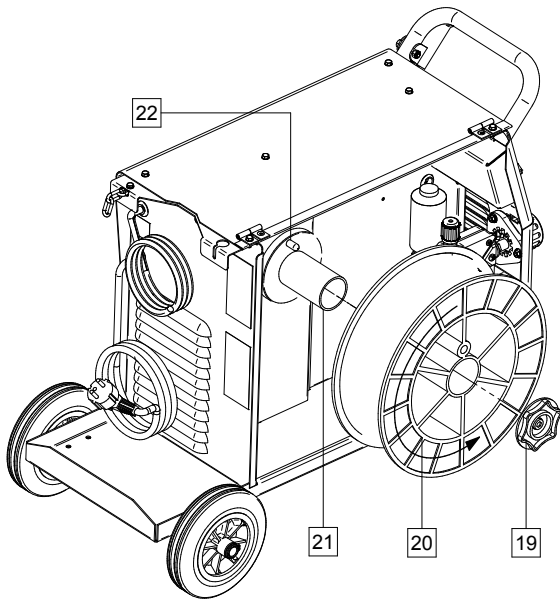

Figure 4

- Turn the input power OFF.
- Open the side panel.
- Unscrew the Locking Nut [19] and remove it from the Spindle [21].
- Place the spool type S300 or BS300 [20] on the Spindle [21] making certain the Spindle Brake Pin [22] is put in the hole in back side of spool type S300 or SB300.

#### WARNING

Position the spool type S300 or SB300 so that it will rotate in a direction when feeding so as to be de-reeled from bottom of the spool.

- Re-install the locking nut [19]. Make sure that the locking nut is tightened.

### Wire Spool Type S200 Loading

#### WARNING

Turn the input power OFF at the welding power source before installation or changing a wire spool.

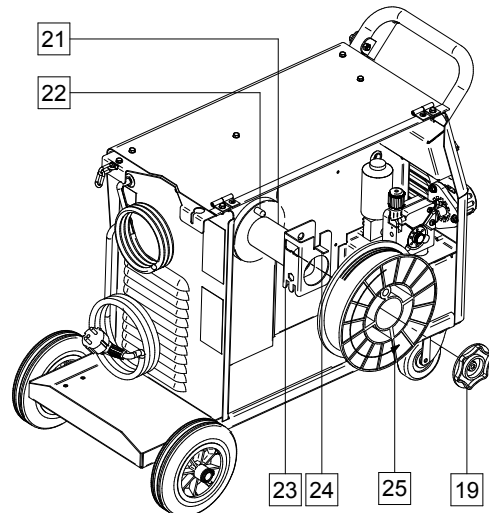

Figure 5

- Turn the input power OFF.
- Open the side panel.
- Unscrew the Locking Nut [19] and remove it from the Spindle [21].
- Place the adapter of spool type S200 [23] on the spindle [21] making certain the spindle brake pin [22] is put in the hole in back side of the adapter [23]. The adapter of spool type S200 can be purchased separately (see "Accessories" chapter).
- Place the spool type S200 [25] on the spindle [21] making certain that the adapter brake pin [24] is put in the hole in the back side of the spool.

#### WARNING

Position the spool type S200 so that it will rotate in a direction when feeding so as to be de-reeled from bottom of the spool.

- Re-install the locking nut [19]. Make sure that the locking nut is tightened.

## Wire Spool Type B300 Loading

### WARNING

Turn the input power OFF at the welding power source before installation or changing a wire spool.

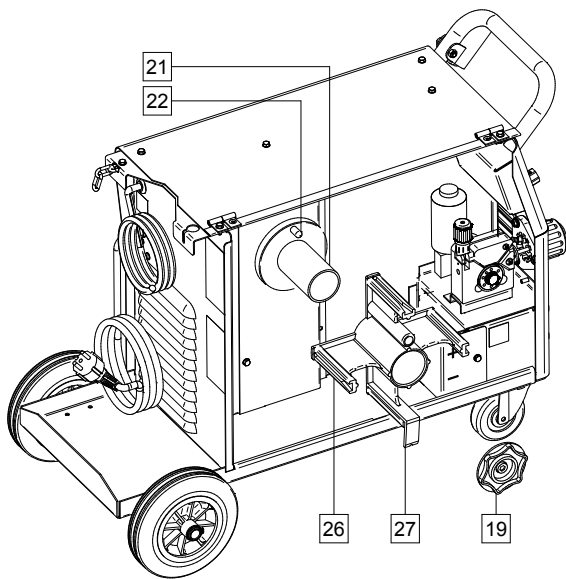

Figure 6

- Turn the input power OFF.
- Open the side panel.
- Unscrew the Locking Nut [19] and remove it from the spindle [21].
- Place the adapter of spool type B300 [26] on the spindle [21]. Make certain that the spindle brake pin [22] is put in the hole in the back side of the adapter [26]. The adapter of spool type B300 can be purchased separately (see "Accessories" chapter).
- Re-install the locking nut [19]. Make sure that the locking nut is tightened.

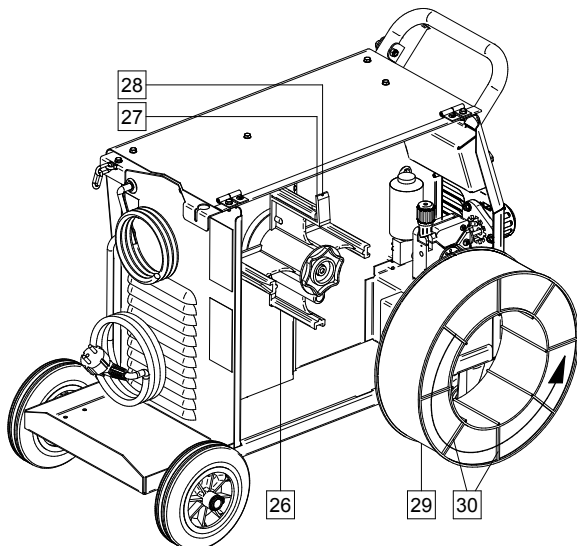

Figure 7

- Rotate the spindle and adapter so the retaining spring [27] is at the 12 o'clock position.

- Place the spool type B300 [29] on the adapter [26]. Set one of the B300 inside cage wires [30] on the slot [28] in the retaining spring tab [27] and slide the spool onto the adapter.

### WARNING

Position the spool type B300 so that it will rotate in a direction when feeding so as to be de-reeled from bottom of the spool.

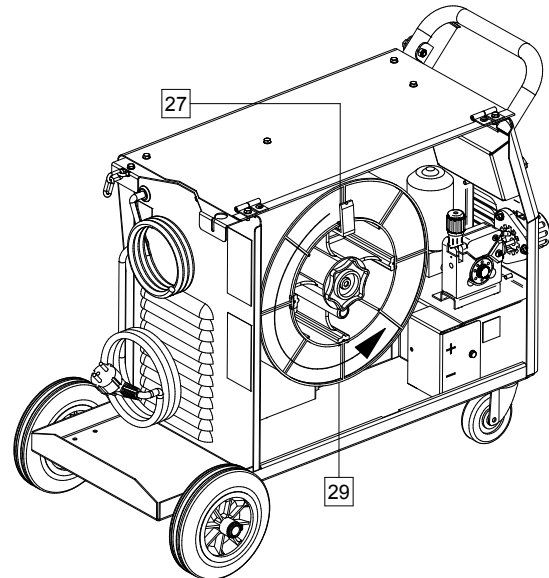

Figure 8

## Wire Spool Type Redi-Reel® Loading

### WARNING

Turn the input power OFF at the welding power source before installation or changing a wire spool.

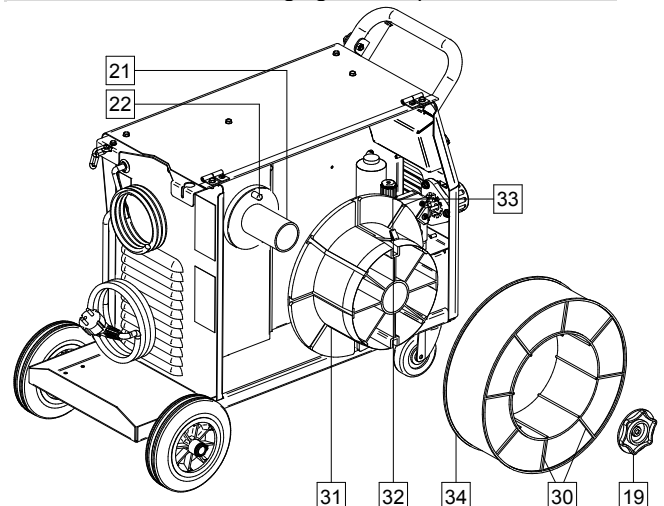

Figure 9

- Turn the input power OFF.
- Open the spool wire case.
- Unscrew the locking nut [19] and remove it from the spindle [21].
- Place the adapter of spool type Redi-Reel® [31] on the spindle [21]. Make certain that the spindle brake pin [22] is put in the hole in the back side of the adapter [31]. The adapter of spool type Redi-Reel® can be purchased separately (see "Accessories" chapter).

- Re-install the locking nut [19]. Make sure that the locking nut is tightened.
- Rotate the spindle and adapter so the retaining spring [32] is at the 12 o'clock position.
- Place the spool type Readi-Reel® [34] on the adapter [31]. Set one of the Readi-Reel® inside cage wires [30] on the slot [33] in the retaining spring tab [32].

**⚠ WARNING**

Position the spool type Readi-Reel® so that it will rotate in a direction when feeding so as to be de-reeled from bottom of the spool.

### Loading the Electrode Wire

- Turn the input power OFF.
- Open the side panel of the machine.
- Unscrew the locking nut of the sleeve.
- Load the spool with the wire [15] on the sleeve such that the spool turns anticlockwise when the wire [14] is fed into the wire feeder.
- Make sure that the spool locating pin goes into the fitting hole on the spool.
- Screw in the locking nut of the sleeve.
- Put on the wire roll using the correct groove corresponding to the wire diameter.
- Free the end of the wire and cut off the bent end making sure it has no burr.

**⚠ WARNING**

Sharp end of the wire can hurt.

- Rotate the wire spool anticlockwise and thread the end of the wire into the wire feeder as far as the Euro socket.
- Adjust force of pressure roll of the wire feeder properly.

### Adjustments of Brake Torque of Sleeve

To avoid spontaneous unrolling of the welding wire the sleeve is fitted with a brake. Adjustment is carried by rotation of its screw M10, which is placed inside of the sleeve frame after unscrewing the fastening cap of the sleeve.

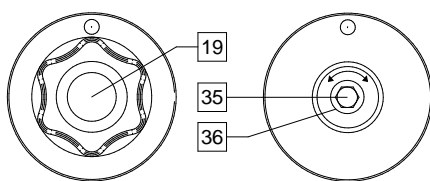

Figure 10

- 19. Fastening cap.
- 35. Adjusting screw M10.
- 36. Pressing spring.

Turning the screw M10 clockwise increases the spring tension and you can increase the brake torque

Turning the screw M10 anticlockwise decreases the spring tension and you can decrease the brake torque.

After finishing of adjustment, you should screw in the fastening cap again.

### Adjusting of Force of Pressure Roll Force

The pressure arm controls the amount of force the drive rolls exert on the wire. Pressure force is adjusted by turning the adjustment nut clockwise to increase force, counterclockwise to decrease force. Proper adjustment of pressure arm gives the best welding performance.

**⚠ WARNING**

If the roll pressure is too low the roll will slide on the wire. If the roll pressure is set too high the wire may be deformed, which will cause feeding problems in the welding gun. The pressure force should be set properly. Decrease the pressure force slowly until the wire just begins to slide on the drive roll and then increase the force slightly by turning of the adjustment nut by one turn.

### Inserting Electrode Wire into Welding Gun

- Turn the input power OFF.
- Depending on welding process, connect the proper gun to the euro socket, the rated parameters of the gun and of the welding machine should be matched.
- Remote the nozzle from the gun and contact tip or protection cap and contact tip. Next, straighten the gun out flat.
- Insert the wire through the guide tube, over the roller and through the guide tube of Euro Socket into liner of gun. The wire can be pushed into the liner manually for a few centimetres, and should feed easily and without any force.

**⚠ WARNING**

If force is required it is likely that the wire has missed the liner of gun.

- Turn the input power ON.
- Depress the gun trigger to feed the wire through the gun liner until the wire comes out of the threaded end.
- When trigger is released spool of wire should not unwind.
- Adjust wire spool brake accordingly.
- Turn the welding machine off.
- Install a proper contact tip.
- Depending on the welding process and the type of the gun, install the nozzle (GMAW process) or protection cap (FCAW-SS process).

**⚠ WARNING**

Take precaution to keep eyes and hands away from the end of the gun while the wire is being come out of the threaded end.

## Changing Driving Rolls

### WARNING

Turn the input power OFF at the welding power source before installation or changing drive rolls and/or guides.

**WELD PAK™<sup>®</sup> 2000** is equipped with drive roll V0.8/V1.0 for steel wire. For others wire sizes, is available the proper drive rolls kit (see "Accessories" chapter) and follow instructions:

- Turn the input power OFF.
- Release the pressure roll lever [37].
- Unscrew the fastening cap [38].
- Change the drive roll [39] with the compatible ones corresponding to the used wire.

### WARNING

Be sure that the gun liner and contact tip are also sized to match the selected wire size.

- Screw fastening cap [38].
- Manually feed the wire from the wire reel, the wire through the guide tubes, over the roller and guide tube of Euro Socket into liner of gun.
- Lock the pressure roll lever [37].

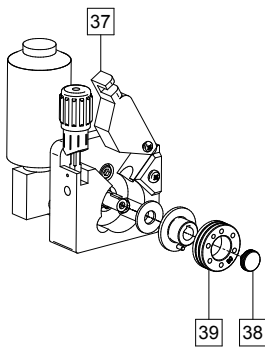

Figure 11

## Gas Connection

A gas cylinder must be installed with a proper flow regulator. Once a gas cylinder with a flow regulator has been securely installed, connect the gas hose [11] to the flow regulator.

### WARNING

The welding machine supports all suitable shielding gases at a maximum pressure of 5,0 bar.

### WARNING

Always fasten gas cylinder properly in vertical position in a special holder on the wall or on a carriage. Remember to close gas cylinder valve after having finished welding.

### WARNING

Gas cylinder can be fasten on the machine's shelf, but the height of gas cylinder doesn't have to be higher than 43in/1,1m. See the Figure 12. The gas cylinder which is fastened on the machine's shelf has to be secured by attaching it to the machine using the chain.

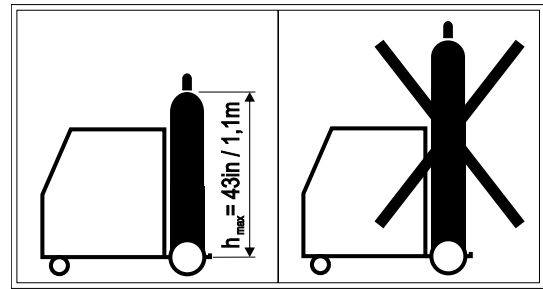

Figure 12

## Welding GMAW, FCAW-SS Process

**WELD PAK™2000** can be used to welding GMAW and FCAW-SS process.

**WELD PAK™2000** includes the gun necessary for GMAW.

Procedure of begin welding of GMAW or FCAW-SS process:

- Place the machine conveniently near the work area in a location to minimize exposure to weld spatter and to avoid sharp bends in the gun cable.
- Determine the wire polarity for the wire to be used. Consult the wire data for this information.
- Connect output the gas-cooled gun to GMAW / FCAW-SS process to Euro Socket [8].
- Depending on the using wire, connect the work lead to output socket [9] or [10]. See [18] point – terminal block of changing polarity.
- Connect the work lead to the welding piece with the work clamp.
- Install the proper wire.
- Install the proper drive roll.
- Manually push the wire into the gun's liner.
- Make a sure, if it is needed (GMAW process), that the gas shield has been connected.
- Turn the machine on.
- Insert the wire into the welding gun.

### WARNING

Keep the gun cable as straight as possible when loading electrode through cable.

### WARNING

Never use defected gun.

- Close the wire drive door.
- Set the welding parameters.
- The welding machine is now ready to weld.

### WARNING

The wire drive door has to be completely closed during welding.

### WARNING

Keep the gun cable as straight as possible when welding or loading electrode through cable.

### WARNING

Do not kink or pull cable around sharp corners.

- By applying the principle of occupational health and safety at welding, welding can be begun.

In manual mode can be set:

- The welding load voltage
- WFS (wire feed speed)
- Inductance

### Welding SMAW (MMA) Process

**WELD PAK™2000** does not include the electrode holder with lead necessary for SMAW welding, but the one can be purchased separately. See "Accessories" chapter.

Procedure of begin welding of SMAW process:

- Determine the electrode polarity for the electrode to be used. Consult the electrode data for this information.
- Depending on the polarity of using electrode, connect the work lead [19] and the electrode holder with lead to output socket [8] or [9] and lock them. See the Table 3.

**Table 3.**

|          |        | Output socket                          |               |
|----------|--------|--|---------------|
| POLARITY | DC (+) | The electrode holder with lead to SMAW | [9] <b>+</b>  |
|          |        | Work lead                              | [10] <b>-</b> |
|          | DC (-) | The electrode holder with lead to SMAW | [10] <b>-</b> |
|          |        | Work lead                              | [9] <b>+</b>  |

- Connect the work lead to the welding piece with the work clamp.
- Install the proper electrode in the electrode holder.
- Turn the welding machine on.
- Set the welding parameters.
- The welding machine is now ready to weld.
- By applying the principle of occupational health and safety at welding, welding can be begun.

User can set functions:

- The welding current
- HOT START
- ARC FORCE

## Maintenance

### **WARNING**

For any repair operations, modifications or maintenances, it is recommended to contact the nearest Technical Service Center or Lincoln Electric. Repairs and modifications performed by unauthorized service or personnel will cause, that the manufacturer's warranty will become null and void.

Any noticeable damage should be reported immediately and repaired.

#### Routine maintenance

- Check condition of insulation and connections of the work leads and insulation of power lead. If any insulation damage exists replace the lead immediately.
- Remove the spatters from the welding gun nozzle. Spatters could interfere with the shielding gas flow to the arc.
- Check the welding gun condition: replace it, if necessary.
- Check condition and operation of the cooling fan. Keep clean its airflow slots.

#### Periodic maintenance

Perform the routine maintenance and, in addition:

- Keep the machine clean. Using a dry (and low pressure) airflow, remove the dust from the external case and from the cabinet inside.
- If it is required, clean and tighten all weld terminals.

The frequency of the maintenance operations may vary in accordance with the working environment where the machine is placed.

### **WARNING**

Do not touch electrically live parts.

### **WARNING**

Before the case of welding machine will be removed, the welding machine had to be turned off and the power lead had to be disconnected from mains socket.

### **WARNING**

Mains supply network must be disconnected from the machine before each maintenance and service. After each repair, perform proper tests to ensure safety.

# WEEE

07/06

|  |  |
|--|--|
| <p>English</p>  | <p>Do not dispose of electrical equipment together with normal waste!</p> <p>In observance of European Directive 2012/19/EC on Waste Electrical and Electronic Equipment (WEEE) and its implementation in accordance with national law, electrical equipment that has reached the end of its life must be collected separately and returned to an environmentally compatible recycling facility. As the owner of the equipment, you should get information on approved collection systems from our local representative.</p> <p>By applying this European Directive you will protect the environment and human health!</p> |
|--|--|

## Spare Parts

12/05

|  |
|--|
| <p><b>Part List reading instructions</b></p> <ul style="list-style-type: none"> <li>Do not use this part list for a machine if its code number is not listed. Contact the Lincoln Electric Service Department for any code number not listed.</li> <li>Use the illustration of assembly page and the table below to determine where the part is located for your particular code machine.</li> <li>Use only the parts marked "X" in the column under the heading number called for in the assembly page (# indicate a change in this printing).</li> </ul> |
|--|

First, read the Part List reading instructions above, then refer to the "Spare Part" manual supplied with the machine, that contains a picture-descriptive part number cross-reference.

## Electrical Schematic

Refer to the "Spare Part" manual supplied with the machine.

## Suggested Accessories

|                  |  |
|------------------|--|
| K10429-15-3M     | The gas-cooled gun LGS150 G-3.0 to GMAW process - 3m   |
| K10429-15-4M     | The gas-cooled gun LGS150 G-4.0 to GMAW process - 4m   |
| K10429-15-5M     | The gas-cooled gun LGS150 G-5.0 to GMAW process - 5m   |
| KP10461-1        | Gas nozzle conical Ø12mm   |
| KP10440-06       | Contact Tip M6x25mm ECu 0.6mm  |
| KP10440-08       | Contact Tip M6x25mm ECu 0.8mm  |
| KP10440-09       | Contact Tip M6x25mm ECu 0.9mm  |
| KP10440-10       | Contact Tip M6x25mm ECu 1.0mm  |
| KP10468          | Protection cap to FCAW-SS process  |
| E/H-200A-25-3M   | Welding cable with electrode holder to SMAW process - 3m   |
| GRD-200A-35-5M   | Work Lead -5m.   |
| KIT-200A-25-3M   | Lead's KIT to SMAW process:<br>The electrode holder with lead to SMAW process - 3m<br>Work lead - 3m |
| R-1019-125-1/08R | Adapter for spool type S200  |
| K10158-1         | Adapter for spool type B300  |
| K363P            | Adapter for spool type Readi-Reel®   |

| Drive rolls to 2 driven rolls |                               |
|-------------------------------|-------------------------------|
| KP14016-0.8                   | Solid wires:<br>V0.6 / V0.8   |
| KP14016-1.0                   | V0.8 / V1.0                   |
| KP14016-1.1R                  | Cored wires:<br>VK0.9 / VK1.1 |